

LAKELAND

INSTRUCTION BOOKLET

COMPACT BREAD MAKER



Model: 16147

LAKELAND COMPACT BREAD MAKER

Thank you for choosing the Lakeland Compact Bread Maker.

We are sure you will be delighted with the performance and will enjoy many years of making and baking your own delicious home-made bread.

Please take a little time to read this booklet before getting started and keep it in a safe place for future reference.

This Compact Bread Maker makes a 1lb / 500g loaf. It is the ideal size for smaller households or for those who like to bake a small loaf of bread every day. It makes the ideal size loaf to freeze easily and the compact neat size gives perfect slices.

Here at Lakeland, our award-winning family-owned business still offers the same excellent quality, value for money and exceptional customer service as when we founded the company back in the 1960s.

Our products are hand-picked and thoroughly tested so you can be sure that everything you purchase will be a pleasure to use for many years to come.

CONTENTS

Product features.....	4
Safety cautions.....	5
The control panel and programmes.....	7
How to assemble the Compact Bread Maker and using for the very first time.....	11
Instructions for use	12
Additional flavourings and ingredients	14
Table for programme cycle times (minutes).....	16
A guide to ingredients.....	16
Adapting your own recipes.....	19
Hints and tips.....	20
Recipes	21
Programme 1 – BASIC	22
Programme 2 – FRENCH	24
Programme 3 – WHOLE-WHEAT	25
Programme 4 – QUICK	26
Programme 5 – SWEET.....	27
Programme 6 – GLUTEN-FREE	28
Programme 7 – ULTRA FAST	29
Programme 8 – DOUGH (Bread Rolls)	30
Programme 8 – DOUGH continued (Pizza).....	32
Programme 9 – CAKE	34
Programme 10 – SANDWICH.....	36
Programme 11 – BAKE	37
Troubleshooting.....	39
Care and cleaning	44
Electrical connections.....	45
Recycling your electricals	45

PRODUCT FEATURES

- | | |
|---------------------------------------|--------------------|
| 1. Measuring spoon | 6. Baking chamber |
| 2. Measuring cup | 7. Control panel |
| 3. Hook | 8. Drive shaft |
| 4. Removable bread pan
with handle | 9. Heating element |
| 5. Kneading paddle | 10. Air vents |
| | 11. Viewing window |

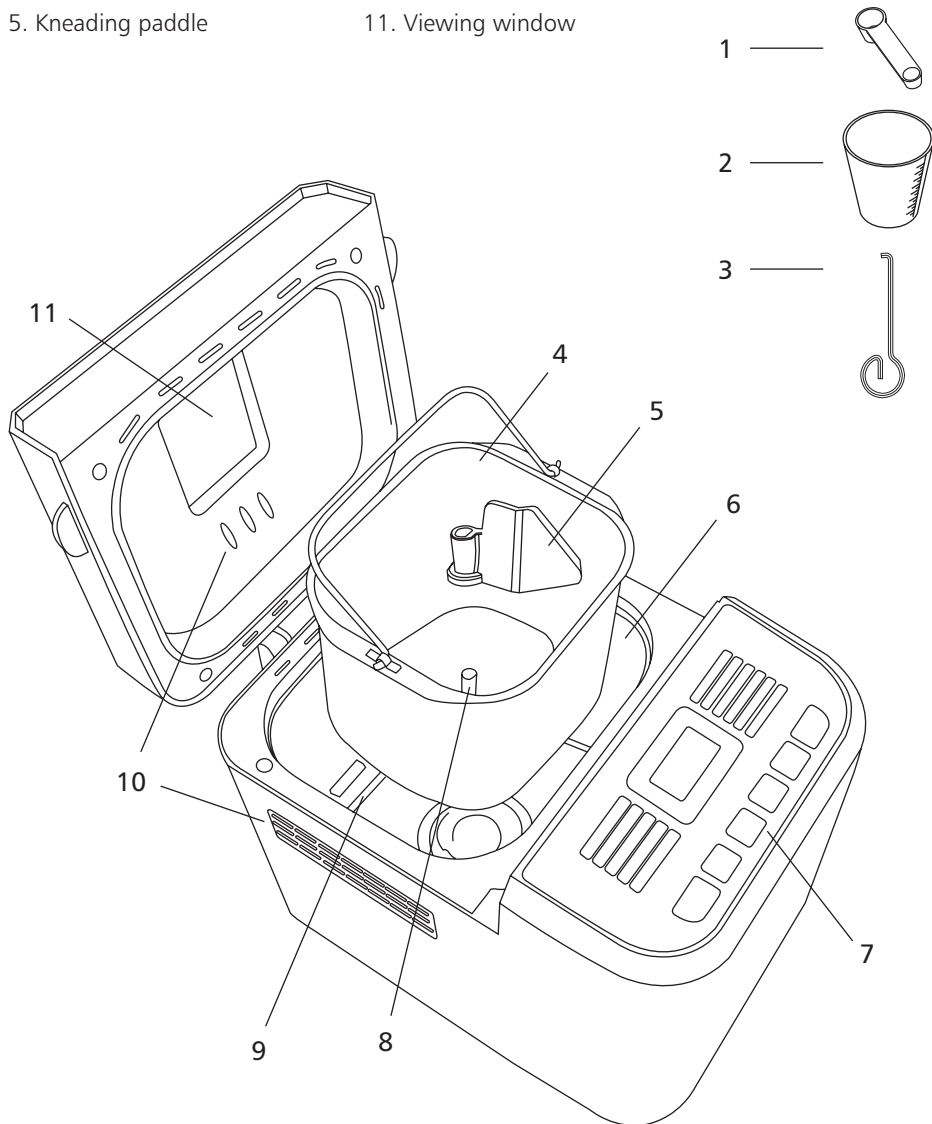

SAFETY CAUTIONS

Carefully read all the instructions before using the appliance and keep in a safe place for future reference. Always follow these safety cautions when using the appliance to avoid personal injury or damage to the appliance. This appliance should be used only as described in this instruction book.

- This appliance can be used by children aged from 8 years and above and persons with reduced physical, sensory or mental capabilities or lack of experience and knowledge if they have been given supervision or instruction concerning use of the appliance in a safe way and understand the hazards involved. Children shall not play with the appliance. Cleaning and user maintenance shall not be done by children unless they are older than 8 and supervised.
- Make sure your electricity supply matches the voltage shown on the appliance.
- Ensure all packaging materials and any promotional labels or stickers are removed from the appliance before the first use.
- Always inspect the appliance before use for noticeable signs of damage. Do not use if damaged or has been dropped. In the event of damage, or if the appliance develops a fault contact the Lakeland customer care team on 015394 88100.
- Do not use this appliance if the lead is damaged. If the lead is damaged it must be replaced with a special lead. Contact the Lakeland customer care team on 015394 88100.
- Always use the appliance on a dry, level, heat resistant surface.
- Unplug from the mains when not in use and before cleaning. To disconnect, turn the socket to "off" and remove the plug from the mains socket. Allow to cool before cleaning the appliance.
- Do not use any accessories or attachments with this appliance other than those recommended by Lakeland.
- To protect against fire, electric shock or personal injury, do not immerse cord, plug or unit in water or other liquids.
- Do not leave the lead hanging over the edge of a kitchen table or worktop. Avoid contact between the lead and hot surfaces.
- For indoor use only.
- For domestic use only.
- This appliance should be used for preparation of food as described within the instructions for use that accompany it.
- Always ensure that your hands are dry before removing the plug from the mains socket. Never pull the plug out of the mains socket by its lead.
- To avoid injury or possible fire, do not cover the appliance when in use.
- Do not connect this appliance to an external timer or remote control system.

- An extension cable may be used with care. The electrical rating of the cable should be at least as great as the appliance. Do not allow the cable to hang over the edge of the worktop or touch any hot surfaces.
- This appliance complies with the basic requirements of Directives 2014/30/EU (Electromagnetic Compatibility) and 2014/35/EU (Low Voltage Directive).
- **WARNING:** A cut off plug inserted into a 13 amp socket is a serious safety (shock) hazard. Ensure the cut off plug is disposed of safely.
-  **CAUTION:** The plastic bags used to wrap this appliance or the packaging may be dangerous. To avoid risk of suffocation, keep these bags out of reach of babies and children. These bags are not toys.
- Do not use foil in the bread maker.
- Do not operate empty unless the instructions advise otherwise e.g. for the first use.
- Do not touch any moving parts whilst in use.
- Do not lift or move the Compact Bread Maker whilst in use.
- Do not cover the Compact Bread Maker or block the air vents in the lid or sides whilst in use.
- Make sure there is plenty of air circulation around the Compact Bread Maker.
- The bread pan will be very hot - always use oven gloves to remove the hot bread pan from the baking chamber.
- The kneading paddle will be very hot after use, always use an oven glove or cloth when handling.
- Do not place hands in the baking chamber after the bread pan has been removed as it will be very hot.

WARNING - HOT SURFACES

- The Compact Bread Maker and surfaces marked with this symbol will get very hot during use. 
- **DO NOT TOUCH** these surfaces as possible injury could occur.
- Wear oven gloves when removing the bread pan from the base unit. Allow the appliance to cool completely before touching these surfaces, handling, moving or storing this appliance.
- Be careful when opening the lid, as hot steam will escape and can burn.



THE CONTROL PANEL AND PROGRAMMES



Fig. 1

The Compact Bread Maker does not have a separate on/off switch. Simply plug in and switch on at the socket.

After switching on the Compact Bread Maker the LCD in the display screen will be illuminated and you will hear a beep.

"1, 3:00" appears in the display screen and the arrow points to MEDIUM (see Fig.1) this is the default setting so it will show this every time you turn on the machine.

START/STOP

For starting and stopping the selected programme.

To START a programme, press the START/STOP button for approx 2 seconds. A short beep will be heard and two dots in the time display begin to flash. The programme will start.

To STOP a programme, press the START/STOP button until you hear a beep. The beep indicates that the programme has been switched off. The display screen will show the default setting again (1, 3:00 – arrow pointing to MEDIUM).

PAUSE

Press the PAUSE button to interrupt the programme at any time (to add ingredients etc.). The machine will pause but the setting will be memorized for 10 minutes.

The outstanding time will flash on the display screen.

To continue the programme simply press the PAUSE button again.

MENU

The MENU button is used to set your selected programme.

Press the MENU button repeatedly to scroll through the menu – the programmes will show in the display screen accompanied by short beeps.

Select your programme by pressing the screen repeatedly. When you see the number of the programme you require together with the programme time – stop pressing.

The programmes are as follows:

1. BASIC - Programme time 3 hours

Kneading, rising and baking normal white or brown bread.

2. FRENCH - Programme time 3 hours 50 minutes

Kneading, rising and baking with a longer rise time. The bread will have a crisper crust and a lighter texture.

3. WHOLE-WHEAT - Programme time 3 hours 40 minutes

Kneading, rising and baking of bread made with whole-wheat flours. Use this programme for all whole-wheat, brown and granary type loaves. It has a longer second rising time.

4. QUICK - Programme time 2 hours 10 minutes

Kneading, rising and baking of bread in a shorter time than the BASIC programme but longer than the ULTRA FAST programme. The programme has shorter rising times. It produces an excellent loaf which will be slightly smaller than that produced from the BASIC programme and it will have a slightly denser texture.

5. SWEET - Programme time 2 hours 55 minutes

Kneading, rising and baking of sweet bread.

6. GLUTEN-FREE - Programme time 3 hours 30 minutes

A special programme for those who use gluten-free flours and baking mixes. The programme has a long second rising time.

The dough is usually more like a batter and is wetter than ordinary doughs.

7. ULTRA FAST - Programme time 1 hour 38 minutes

Kneading, rising and baking in the shortest time. The programme has only one rise and two kneads. Loaves baked using this programme require warm water, extra yeast and less salt. The loaf it produces will be smaller with a denser texture than bread made using the QUICK programme. This programme is ideal if you want to make a loaf very quickly.

8. DOUGH - Programme time 1 hour 30 minutes

Kneading and rising. No bake. You can remove the raw dough and shape into rolls, pizzas etc to cook in the conventional oven. Ideal if you like to make your dough in the Bread Maker and then oven bake your loaf.

9. CAKE - Programme time 1 hour 50 minutes

This programme is for producing tea loaves or cakes containing baking powder or baking soda and eggs rather than yeast dough. The cake programme mixes and bakes the cake. You may find that cakes made in the Bread Maker will be smaller and a little more dense than those baked in a conventional oven but will be just as moist.

10. SANDWICH - Programme time 3 hours

Kneading, rising and baking light-textured bread with a thinner crust – ideal for making sandwiches.

11. BAKE - Programme time 1 hour

This is usually used in conjunction with the DOUGH programme to allow additional ingredients to be kneaded into the dough by hand. After completion of the DOUGH programme, remove the unbaked dough, carefully remove the kneading paddle, and reshape the dough, kneading in the additional ingredients such as nuts, fruit etc, then return dough to bread pan and place back in the machine. Close the lid and leave the dough to rise for approximately 30 - 40 minutes.

Select BAKE to cook the loaf.

You can also use the BAKE programme to darken crusts if the finished loaf is too light at the end of your chosen programme. Simply select BAKE and leave the loaf to bake for longer, taking the loaf out of the machine when you are happy with the colour. Bread can also be crisped and freshened using the BAKE programme.

COLOUR

Press the COLOUR button to select a LIGHT, MEDIUM or DARK coloured crust. This cannot be used with the DOUGH setting.

TIME + and TIME –

(DELAYING THE START TIME) (Maximum delay time is 13 hours).

If you want to delay the start time so that the bread cooks overnight and is ready to eat in the morning:-

Example;

It is 8.30pm and you want your bread ready at 7am the following day – i.e. in 10 hours and 30 minutes.

Select your programme and colour.

Press **TIME +** or **TIME –** to add the time until 10.30 appears on the display screen. The time is set in increments of 10 minutes.

Press the START/STOP button to activate the delay function.

The dots will flash and the numbers will count down to show you the remaining time. The bread will be ready for you at 7am.

DO NOT USE THE DELAY TIME WHEN USING INGREDIENTS THAT WOULD SPOIL SUCH AS EGGS, MILK, CREAM OR CHEESE.

NOT SUITABLE FOR GLUTEN-FREE AND ULTRA FAST PROGRAMMES.

WE DO NOT RECOMMEND USE OF DELAY TIME SETTING WITH BREAD MIXES AS YOU CANNOT SEPARATE THE YEAST FROM THE LIQUID.

OTHER FEATURES

AUDIBLE ALERT TO TELL YOU WHEN TO ADD ADDITIONAL INGREDIENTS

Part way through each programme (after approximately 30 minutes but it will vary according to the programme you have selected) the machine will beep 10 times. This tells you that you can add additional ingredients such as fruit, olives, nuts etc. (see page 14 for further information on adding additional flavourings and ingredients). The beeps are very clear and can be easily heard, calling you back to the machine.

KEEP WARM

The Compact Bread Maker will keep the bread warm for 60 minutes after baking. (Not with DOUGH programme). At the end of the programme the Compact Bread Maker will beep and the display screen will show 0:00 indicating that the machine is in keep warm mode.

Note: For best results however, remove the bread as soon as the baking cycle is complete and allow it to cool on a cooling rack. You may find that the crust becomes crisper if kept on the keep warm mode after baking.

POWER FAILURE BACKUP SYSTEM

The Compact Bread Maker is equipped with a power failure backup system or memory. If the power system is interrupted during the course of bread making, the process of making bread will be continued automatically within 10 minutes, even without pressing the START/STOP button. If the interruption time exceeds 10 minutes, the memory cannot be kept and you must discard the ingredients in the bread pan and start again. If the dough has not entered the rising phase when the power supply breaks off, you can press the START/STOP button directly to continue the programme from the beginning.

WARNING DISPLAY

If the display screen shows "H HH" after you have pressed the START/STOP button and the machine beeps continuously the temperature inside is too high. Stop the programme, open the lid and allow the Compact Bread Maker to cool down for 10 - 20 minutes.

If the display screen shows "L LL" after pressing the START/STOP button and the machine beeps continuously the temperature inside is too low. Press the START/STOP button, open the lid and allow the Compact Bread Maker to rest for 10 - 20 minutes to return to room temperature.

If the display screen shows "E EO" or "E E1" after the START/STOP button has been pressed the temperature sensor has developed a fault. Contact Lakeland Customer Services for further advice.

HOW TO ASSEMBLE THE COMPACT BREAD MAKER AND USING FOR THE VERY FIRST TIME

When the Compact Bread Maker is used for the first time it may emit a slight burning smell when first switched on. This is completely normal with a new heating element.

You will need to operate the Compact Bread Maker empty for the very first use. This will also show you how easy the Compact Bread Maker is to use.

- Unpack the Compact Bread Maker, remove all the packaging materials.
- Wash the bread pan and kneading paddle in hot, soapy water, rinse and dry thoroughly.
- Place the Compact Bread Maker on a flat, dry surface.
- Position the bread pan in the baking chamber holding it at a slight angle and turning it clockwise until it clicks into place.
- Fix the kneading paddle onto the drive shaft.
- Close the lid.
- Switch on at the socket.
- The Compact Bread Maker will beep and the display screen will show the default setting 1,3:00.
- Press the MENU button repeatedly – the programme numbers will scroll through. Stop pressing at programme number 11, 1:00 (BAKE). If you go past the number you require simply keep pressing until programme 11 comes round again.
- Select programme 11 (BAKE) and press START/STOP.
- The Compact Bread Maker will begin to count down and you can follow this on the display screen. Leave the Compact Bread Maker to BAKE for 10 minutes. You will hear some intermittent clicks during this time.
- Press the START/STOP button firmly to stop the programme.
- Open the Compact Bread Maker and allow cooling completely.
- Lift out the kneading paddle then remove the bread pan by turning anti-clockwise and lifting out.
- Wash, rinse and dry the bread pan and kneading paddle again and replace.
- The Compact Bread Maker is now ready to use.

INSTRUCTIONS FOR USE

HOW TO MEASURE INGREDIENTS

One of the most important steps for making good bread is to use the exact measure of ingredients. Always use the measuring cup and spoon provided with your Compact Bread Maker. If you prefer to use kitchen scales, metric measurements have also been included in the recipe section.

- Any liquid should be measured with the measuring cup or spoon provided. Observe the level of the measuring cup at eye level.
- When measuring cooking oil or other liquids, wash, rinse and dry the measuring cup and spoon thoroughly before measuring any other ingredients.
- Dry measuring must be done by gently spooning ingredients into the measuring cup and then, once filled, level it off with a knife. Do not be tempted to add more than required or to pack it down tightly into the cup as it will affect the recipe.
- When measuring small amounts of dry or liquid ingredients, use the measuring spoon supplied. Measurements must be level, not heaped, as this could affect the recipe.
- The maximum quantity of flour you should use is 2½ cups, 375g; the maximum amount of yeast is 5g, 2 teaspoons.

The measuring cup holds 160g of flour, or 250ml

1 teaspoon = 5ml

1 tablespoon = 15ml

MAKING A LOAF – Things to remember

How to put the ingredients into the bread pan;

Ensure the ingredients are put into the Compact Bread Maker in the exact order given in the recipe, for example;

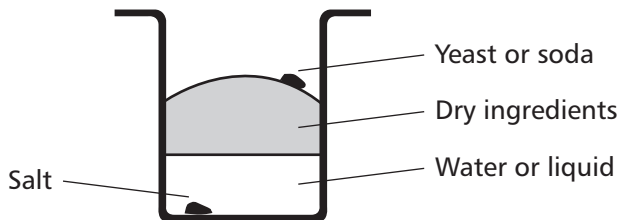

First liquid ingredients at room temperature or as specified in the recipe.

Second dry ingredients. Add the flour gently and make sure it is evenly distributed over the liquid. If you tip it onto the liquid too fiercely the liquid may seep up through the flour and affect the action of the yeast. This is particularly important if you are using the time delay.

Last yeast. The yeast must be kept separate from the wet ingredients and salt. Create a small hole in the dry ingredients using your finger or a spoon and place the yeast in the hole.

Make sure the yeast is fresh – check the use by date.

Ensure the ingredients are at room temperature unless otherwise stated. Water should be cold unless the recipe states otherwise (as in ULTRA FAST programme).

Rub a little margarine or butter onto the kneading paddle and position onto the drive shaft. This prevents the dough from sticking to the kneading paddle and assists with removing the paddle from the bread after baking.

Select your recipe – it is a good idea to use one of the recipes we have included in this booklet. The BASIC bread recipe on page 22 is a good recipe to start with. When you are familiar with the Compact Bread Maker you can use or adapt your own recipes.

1. Add the ingredients to the bread pan as recommended in the recipe.
2. Close the lid.
3. Switch the Compact Bread Maker on. You will hear a beep. The display panel will illuminate and show the default setting (1, 3.00 the arrow pointing to MEDIUM).
4. Press the MENU button repeatedly until the programme you require is reached.
5. Press the COLOUR button to select the desired crust colour (LIGHT, MEDIUM or DARK).
6. If you want to delay the time the Compact Bread Maker will start press the TIME + or TIME - button (for full details see page 9). Skip this step if you want the Compact Bread Maker to start immediately.
7. Press the START/STOP button firmly for 3 seconds. Once you have pressed the START/STOP button the Compact Bread Maker will automatically take care of each step of the bread making process until the loaf is completely cooked. The remaining time will countdown on the display screen.

Check the dough after a few minutes to make sure that all the flour is incorporated into the dough. Sometimes flour may be left in the corners of the bread pan. Press the PAUSE button, open the lid and, using a non-stick spatula, simply loosen the flour so it will be evenly mixed in.

Close the lid again and press PAUSE to recommence the programme.

8. During each programme, after approximately 30 minutes, but this will vary according to the programme you have selected, you will hear 10 beeps – this tells you that you can add additional ingredients at this stage. Open the lid, add the ingredients and close the lid again. There is no need to pause the machine. See “Additional flavourings and ingredients” on page 14.
9. When the programme is complete you will hear 10 beeps and the display screen will show 0:00 the bread will now be automatically kept warm for 60 minutes if you do not switch the Compact Bread Maker off.
10. Press the START/STOP button firmly to stop the machine. The default setting will appear in the display screen (1, 3:00).
11. Open the lid and using an oven glove, turn the bread pan anti-clockwise and gently pull the pan straight up out of the machine using the handle.

12. Turn the bread pan upside down and gently shake the loaf onto a cooling rack. If the loaf does not fall out straight away gently loosen the sides of the loaf with a non-stick spatula.
13. Leave the loaf to cool for at least 20 - 30 minutes. Sometimes the kneading paddle may remain in the loaf. If it does, use the hook to remove the paddle from the base of the loaf. Take care as the kneading paddle will be very hot. Always remove the kneading paddle before slicing the loaf.

Remember; if you do not stop the Compact Bread Maker and remove your loaf the Compact Bread Maker will automatically switch to Keep Warm mode. Your bread will be kept warm for 60 minutes to prevent it from becoming soggy.

For best results, remove the bread as soon as the baking cycle is complete and allow it to cool on a cooling rack.

ADDITIONAL FLAVOURINGS AND INGREDIENTS

You can add many different flavours and ingredients to make a wide variety of delicious breads for example nuts, seeds, fresh or dried herbs, sun dried tomatoes, olives, fruit, chocolate etc. the list is endless.

There are two ways you can add these;

1. At the very start – with the main ingredients

If you add the ingredients at the start you will find that they will be very finely distributed throughout the bread as they will be subjected to the vigorous bread making cycles.

For example if you add sun dried tomatoes at the start you will lose the texture of the tomatoes but will get an attractive coloured bread with a delicious flavour and aroma but pieces of tomato will not be detected in the dough. If you add them later on in the cycle you will retain the texture of the tomatoes.

Foods such as herbs, small seeds e.g. sunflower, sesame or poppy seeds, cheese etc. can be added at the start because they will not lose their texture in the same way.

2. Before the final kneading, rising and baking cycle (the Compact Bread Maker emits 10 beeps to call you to the machine).

If you add ingredients before the final kneading and rising cycle the ingredients will be distributed throughout the dough and will retain more of their shape and texture.

Open the lid after you hear the beeps and add your additional ingredients at this stage. If you prefer you can add some of the ingredients at the very start so they add an overall flavour and colour to the dough, retaining some to add later in the cycle so you have some bigger pieces in the finished bread.

Note

If you are delaying the start time you will need to put all the ingredients into the bread pan at the beginning. You will also need to consider the moisture content of additional ingredients. Juicy dried apricots or roasted red peppers may add as much as a tablespoon of juice as they go through the kneading process. Also, because too much sugar can interfere with the action of yeast, high sugar additives like candied peel should be added late in the kneading cycle.

Bread maker cycles

Once you start a selected programme the appliance will automatically take care of each step of the bread making process until the loaf finishes baking. The display screen will count down and show the remaining time.

Delay time

This allows you to delay the bread making process for up to 13 hours.

Knead

Two kneads are standard for most settings. The first knead will actually mix the ingredients.

Rest

These are periods of resting in which the unit will not be active except for the countdown display.

Rise

These are periods of rising in which the unit will not be active except for the countdown display.

Bake

The loaf is in the final baking cycle. Baking time and temperature will be regulated according to the individual recipe.

Keep warm

The Compact Bread Maker will automatically go into Keep Warm mode at the end of the baking cycle. It will stay in this mode for 1 hour or until the machine is switched off. This means bread can be served warm; it also helps to minimize moisture build up if the loaf is not removed from the Compact Bread Maker immediately after baking.

TABLE FOR PROGRAMME CYCLE TIMES (MINUTES)

	1 Basic	2 French	3 Whole Wheat	4 Quick	5 Sweet	6 Gluten Free	7 Ultrafast	8 Dough	9 Cake	10 Sandwich	11 Bake
1st knead	10	10	10	10	10	12	10	20	6	15	-
1st rise	20	40	25	10	5	15	-	-	5	35	-
2nd knead	15	20	20	10	15	13	5	-	10	10	-
2nd rise	70	85	100	30	80	105	33	70	9	65	-
Bake	65	75	65	70	65	65	50	-	80	55	60
Total time	03:00	03:50	03:40	02:10	02:55	03:30	01:38	01:30	01:50	03:00	01:00

A GUIDE TO INGREDIENTS

The major ingredient in bread making is flour, so selecting the right one is the key to a successful loaf.

Wheat flours

Wheat flours make the best loaves. Wheat consists of an outer husk, often referred to as bran, and an inner kernel which contains the wheat germ and endosperm. It is the protein within the endosperm which, when mixed with water, forms gluten. Gluten stretches like elastic and the gases given off by the yeast during fermentation are trapped, making the dough rise.

Strong White Bread flours

These flours have the outer bran and wheat germ removed, leaving the endosperm which is milled into a white flour. It is essential to use strong white flour or white bread flour because this has a higher protein level essential for the development of the gluten. Do not use ordinary plain white flour or self raising flour for making yeast raised breads in the Compact Bread Maker because you will not get a good result. There are several brands of white bread flour in the shops – look for STRONG or BREAD flour on the bag.

Strong Wholemeal or Whole-wheat Bread flours

Wholemeal flours include the bran and wheat germ and have a nutty flavour. Wholemeal flour gives coarser textured bread. Again look for STRONG wholemeal bread flour. If you make a loaf using all wholemeal flour it will be denser than white loaves. Wholemeal doughs rise more slowly which is why there is a special programme on this machine. For a lighter loaf replace part of the wholemeal flour with white flour.

Granary Strong Bread flours

A combination of white, wholemeal and rye flours with malted whole-wheat grains, which adds texture and flavour. You can use this on its own or in combination with strong white flour.

Non Wheat flours

Other flours such as rye can be used with white and wholemeal bread flours to make traditional breads like pumpernickel or rye bread. Adding even a small amount can add an interesting tang to your loaf. Do not use it on its own as the dough will be very sticky and the loaf will be heavy and very dense.

Other grains e.g. millet, barley, buckwheat, cornmeal and oatmeal;

These grains cannot be used alone to make bread as they are unsuitable but they can be added in small quantities to white bread flour – try replacing 10 - 20% of white bread flour with any of these.

Salt

A small quantity of salt is essential for bread making. It helps to develop the dough and gives flavour. Use fine table salt or sea salt rather than coarse ground salt which is best kept for sprinkling on top of hand-shaped rolls etc to give a crunchy texture. Low salt substitutes are best avoided as most do not contain sodium.

- Salt strengthens the gluten structure and makes the dough more elastic.
- Salt inhibits the growth of yeast to prevent over-rising and stops the dough collapsing.
- Take care to add the correct amount as too much salt will kill the yeast or prevent it rising sufficiently.

Sweeteners

Use white or brown sugars, honey, malt extract, golden syrup, maple syrup, molasses or treacle.

- Sugar and liquid sweeteners help with the colour of the bread and add a golden colour to the crust.
- Sugar attracts moisture which improves the keeping quality of the bread.
- Sugar provides food for the yeast. It is not essential as modern types of dried yeast are able to feed on the natural sugars and starches found in the flour but it will help to make the dough more active.
- Sweet breads have a moderate level of sugar with the fruit, glaze or icing adding extra sweetness. Use the SWEET programme for these breads.
- If substituting a liquid sweetener for sugar then the total liquid quantity of the recipe will need to be reduced slightly.

Fats and oils

A small amount of fat or oil will give a softer crumb and helps to extend the freshness of the loaf. Use butter, margarine or lard in small quantities. Do not use low fat spreads as they contain up to 40% water and can affect the overall quantities in your recipe.

Liquid

Some form of liquid is essential. Usually water or milk is used. Water gives a crisper result than milk. Water can be combined with skimmed milk powder. If using the time delay it is important to use water and skimmed milk powder as ordinary milk will deteriorate if left to stand for too long. For most programmes you can use water straight from the tap but if using the ULTRA QUICK programmes it needs to be lukewarm.

- On very cold days measure the water and leave to stand at room temperature for 30 minutes before use.
- If using milk, don't use it straight from the fridge, leave it to stand at room temperature for 30 minutes before use.
- Buttermilk, yoghurt, sour cream and soft cheeses such as Ricotta, cottage or fromage frais can all be used as part of the liquid content and will give a more moist and tender crumb.
- Eggs can be added to the dough to enrich it. Eggs improve the colour and help to add structure and stability to the gluten during rising. If you are using eggs, reduce the liquid content accordingly. Place the egg in the measuring cup and top up with liquid to the correct level for the recipe.

Yeast

All the recipes in this book have been tested using easy blend, fast-action yeast which does not require dissolving in water first, is very easy to use and tends to give better results. It is placed in a well in the flour where it is kept dry and separate from the liquid until the mixing commences.

- For best results use easy blend, fast-action yeast.
- Use only the amount of yeast stated in the recipe. If too much is added it will cause the dough to spill out over the top of the bread pan.
- Once a sachet of yeast is opened it should be used within 48 hours.
- Always use yeast before its use by date.
- You may also find dried yeast that has been specially designed for use in bread makers.
- Always follow the instructions on the packet.

ADAPTING YOUR OWN RECIPES

After you have made some of the recipes supplied you may wish to adapt a few of your own recipes.

Start by selecting one of the recipes in this booklet, which is similar to your own and use this as a guide.

Read through the following guidelines and be prepared to make adjustments as you go along.

- Make sure you use the correct quantities for the Compact Bread Maker. This Compact Bread Maker makes a 500g loaf. Do not exceed the recommended maximum. If using your own recipe books always use the quantities given for the 500g loaf size.
- Always add the liquid to the bread pan first. Separate the yeast from the liquid by adding after the flour.
- Add the flour carefully and spread it over the liquid. If tipped in too fiercely, the liquid may seep up through the flour and come into contact with the yeast.
- Replace fresh yeast with easy blend dried yeast. Note: 6g fresh yeast = 1 teaspoon (5ml) dried yeast.
- Use skimmed milk powder and water instead of fresh milk if you are delaying the start time.
- If your recipe uses egg, add the egg as part of the total liquid measurement, unless the recipe states otherwise.
- Keep the yeast separate from the other ingredients in the bread pan until mixing commences.
- Check the consistency of the dough during the first few minutes of mixing. Bread makers do require slightly softer dough so you may have to add extra liquid. The dough should be wet enough to gradually relax back.

REMOVING, SLICING AND STORING BREAD

- For best results, once your loaf is baked, remove it from the machine and turn out of the bread pan immediately, although your Compact Bread Maker will keep it warm for up to an hour if you are not around.
- Remove the bread pan from the machine using oven gloves, even if it is during the KEEP WARM cycle. Turn the pan upside down and shake several times to release the cooked bread. If the bread is difficult to remove, try gently knocking the corner of the bread pan on a wooden board, or rotate the base of the shaft underneath the bread pan.
- The kneading paddle should remain inside the bread pan when the bread is released but occasionally it may remain inside the loaf of bread. If so, remove it using the hook before slicing the bread.
- Leave the bread to cool for at least 30 minutes on a cooling rack, to allow steam to escape. The bread will be difficult to slice if hot.

Storing

Home-made bread does not contain any preservatives so should be eaten within 2 - 3 days of baking. If you are not eating it immediately, wrap in foil or place in a plastic bag and seal.

- Crispy, French-style bread will soften on storage so it is best left uncovered until sliced.
- If you wish to freeze your bread, slice the loaf before freezing so you can take out just the slices you need.

HINTS AND TIPS

- The Compact Bread Maker is not a sealed unit and will be affected by the temperature and humidity of the day. If it is a very hot day or the machine is used in a hot kitchen, then the bread is likely to rise more than if it is cold.
- On very cold days let the water from the tap stand at room temperature for 30 minutes before use. Likewise for ingredients from the fridge.
- Use all the ingredients at room temperature and water from cold unless stated otherwise in the recipe e.g for the ULTRA FAST programme when you will need to warm the liquid.
- Add the ingredients to the bread pan in the order suggested in the recipe. Keep the yeast dry and separate from any other liquids added to the pan, until mixing commences.
- Accurate measuring is vital for a successful loaf. Follow either metric or imperial measurements, do not mix the two. Use the measuring cup and spoon supplied or use accurate kitchen scales.
- Always use fresh ingredients, within their use by date. Perishable ingredients such as milk, cheese, vegetables and fresh fruits may deteriorate, especially in warm conditions. These should only be used in breads which are made immediately.
- Do not add too much fat as it forms a barrier between the yeast and flour, slowing down the action of the yeast, which could give a heavy, dense loaf.
- Cut butter and other fats into small pieces before adding to the bread pan.
- Giving the kneading paddle a light coating of oil may make it easier to remove if it bakes into the loaf.
- You may find that baked loaves may be left with a small patch of unmixed flour, this is quite normal and can simply be brushed off.
- Bread made in the Bread Maker does not contain preservatives like shop bought bread and so will not keep for as long.

RECIPES

- The Compact Bread Maker will make a 500g loaf.
- Use the measuring cups and spoon supplied. Alternatively, ingredients can be weighed using your kitchen scales.
- Follow quantities accurately.
- The recipe charts show the sequence the ingredients are added to the bread pan.
- There is a recipe for each programme.

Packet bread mixes

You can use packet bread mixes in your bread maker. The pack should give instructions for use. Make sure you do not exceed the maximum amount the Compact Bread Maker can handle.

Do not use bread mixes with time delay as you cannot separate the yeast from the liquid. Please note that all spoon measurements are standard metric, so 1 tsp is 5ml and 1 tbsp is 15ml. We recommend using the measuring spoon included for accurate results.

PROGRAMME 1 - BASIC

BASIC BREAD - Time to make 3 hours

This is an excellent basic loaf. You can enrich the bread by adding an egg which will give a delicious flavour. When using egg, remember to include this in the total liquid quantity so;

Put the egg in the measuring cup and top up to 180ml with water.

You can add extra ingredients to this basic bread such as nuts, herbs, sun dried tomatoes, olives etc. (See page 14 Additional flavourings and ingredients).

Ingredients	Quantity
Water	180ml
Oil	1 tablespoon (15ml)
Salt	1 teaspoon
Strong white bread flour	2 cups (320g)
Caster sugar	1 tablespoon
Milk powder	1 tablespoon
Easy blend yeast	1 teaspoon

VARIATIONS – You can add any of these ingredients to the basic bread

Ingredients	Quantity
Nuts e.g. walnuts	25g
Poppy seeds	15g
Cheese, grated	50g
Sund dried tomatoes, chopped	25g
Olives, cut into pieces	25g
Seeds	25g

WHAT YOU DO

Put all the ingredients in the order above into the bread pan.

Close the lid.

The display screen will show 1, 3:00 which is the default setting. This is also the BASIC programme so you do not need to press the MENU button.

Press COLOUR to select the crust – LIGHT, MEDIUM or DARK.

Press the START/STOP button.

The Compact Bread Maker will start immediately.

When the Compact Bread Maker beeps 10 times you can add any additional ingredients.

The programme will continue until the end and will then beep 10 times to indicate that the bread is ready.

Press the START/STOP button and open the lid.

Lift out the bread pan; remove the bread and leave to cool.

PROGRAMME 2 - FRENCH

FRENCH BREAD - Time to make 3 hours 50 minutes

This is a tasty French style bread with a lighter texture and crisper crust. French bread is usually made with French bread flour, however it may be difficult to find. This recipe uses ordinary strong white bread flour and gives excellent results. French bread flour can be found in some shops and online.

Ingredients	Quantity
Water	190ml
Oil	1 tablespoon (15ml)
Salt	1 teaspoon
Strong white bread flour	2½ cups (375g)
Caster sugar	1 tablespoon
Easy blend yeast	1 teaspoon

WHAT YOU DO

Put the ingredients into the bread pan in the order above.

Close the lid.

Press MENU and select programme 2.

Press COLOUR and select LIGHT, MEDIUM or DARK.

Press START/STOP.

When the Compact Bread Maker beeps 10 times you can add any additional ingredients.

The programme will continue until the end and will beep again 10 times to indicate that the bread is ready.

Press START/STOP and open the lid.

Remove the loaf from the bread pan and leave to cool.

French bread is best eaten fresh as it will soften if kept.

PROGRAMME 3 - WHOLE-WHEAT

WHOLE-WHEAT BREAD - Time to make 3 hours 40 minutes

This bread uses half wholemeal strong bread flour and half white strong bread flour. You can use all wholemeal flour but the result will be denser in texture.

Ingredients	Quantity
Water	180ml
Oil	1 tablespoon (15ml)
Salt	1½ teaspoons
Strong wholemeal flour	1 cup (160g)
Strong white bread flour	1 cup (160g)
Caster sugar	1 teaspoon
Milk powder	1 tablespoon
Easy blend yeast	1 teaspoon

You can add additional ingredients to brown bread – seeds and grains are particularly good. These can be added at the beginning of the programme with the other ingredients or when the beep sounds.

Ingredients	Quantity
Nuts e.g. walnuts	25g
Poppy seeds	15g
Cheese, grated	50g
Sunflower seeds	25g
Fennel seeds, caraway seeds, cumin seeds etc.	15g

WHAT YOU DO

Put the ingredients into the bread pan in the order above.

Close the lid.

Press MENU and select programme 3.

Press COLOUR and select LIGHT, MEDIUM or DARK.

Press START/STOP.

When the Compact Bread Maker beeps 10 times you can add any additional ingredients.

The programme will continue until the end and will then beep again 10 times to indicate that the bread is ready.

Press START/STOP and open the lid.

Remove the loaf from the bread pan and leave to cool.

PROGRAMME 4 - QUICK

QUICK BREAD - Time to make 2 hours 10 minutes

Ingredients	Quantity
Egg	1 medium
Milk	Make up to 180ml with the egg
Oil	2 tablespoons (30ml)
Salt	1 teaspoon
Strong white bread flour	2 cups (320g)
Soft light brown sugar	4 tablespoons
Milk powder	2 tablespoons
Easy blend yeast	2 teaspoons

WHAT YOU DO

Crack the egg into the measuring cup and make up to 180ml, 6½ fl oz with the milk

Put the ingredients into the bread pan in the order above.

Close the lid.

Press MENU and select programme 4.

Press COLOUR and select LIGHT, MEDIUM or DARK.

Press START/STOP.

When the Compact Bread Maker beeps 10 times you can add any additional ingredients.

The programme will continue until the end and will then beep again 10 times to indicate that the bread is ready.

Press START/STOP and open the lid.

Remove the loaf from the bread pan and leave to cool.

PROGRAMME 5 - SWEET

CRANBERRY, ALMOND AND PECAN BREAD - Time to make 2 hours 55 minutes

A delicious bread which is ideal for a weekend breakfast treat.

Ingredients	Quantity
Water	150ml
Natural plain yoghurt	100ml
Salt	½ teaspoon
Strong white bread flour	2½ cups (375g)
Ground almonds	3 tablespoons
Caster sugar	3 tablespoons
Easy blend yeast	1 teaspoon
Pecan nuts, coarsely chopped	50g
Dried cranberries	75g
A little warmed honey for brushing	

WHAT YOU DO

Put the ingredients, except the pecan nuts and cranberries, into the bread pan in the order above.

Close the lid.

Press MENU and select programme 5

Press COLOUR and select LIGHT, MEDIUM or DARK.

Press START/STOP.

When the Compact Bread Maker beeps 10 times open the lid and add the pecans and cranberries.

The programme will continue until the end and will beep again 10 times to indicate that the bread is ready.

Press START/STOP and open the lid.

Remove the loaf from the bread pan and leave to cool.

Brush the top of the loaf with warmed honey to finish.

PROGRAMME 6 - GLUTEN-FREE

STANDARD GLUTEN-FREE LOAF - Time to make 3 hours 30 minutes

Use a gluten-free bread flour blend for this recipe.

The bread has a dense texture and has a lower rise than ordinary bread.

You can add any seeds, nuts or dried fruits to this recipe.

Ingredients	Quantity
Water	150ml
Oil	3 tablespoons (45ml)
Runny honey	¼ cup (100g)
Cider vinegar	1 teaspoon
Egg, medium	1
Salt	½ teaspoon
Gluten free bread flour blend	2 cups (320g)
Caster sugar	2 tablespoons
Easy blend yeast	1 teaspoon

WHAT YOU DO

Put the ingredients into the bread pan in the order above.

Close the lid.

Press MENU and select programme 6.

Press COLOUR and select LIGHT, MEDIUM or DARK.

Press START/STOP.

When the Compact Bread Maker beeps 10 times you can add any additional ingredients.

The programme will continue until the end and will then beep again 10 times to indicate that the bread is ready.

Press START/STOP and open the lid.

Remove the loaf from the bread pan and leave to cool, **DO NOT leave on KEEP WARM mode.**

PROGRAMME 7 - ULTRA FAST

ULTRA FAST WHITE BREAD - Time to make 1 hour 38 minutes

This programme cooks a loaf of bread in the shortest time.

Use lukewarm water to help speed up the rising process (32 - 35°C / 90 - 95°F) is optimum. Cold water will result in a shorter loaf. If the water is too hot it will kill the yeast. For best results mix 25% boiling water with 75% cold water.

Bread recipes should contain at least 65% strong white bread flour on this programme. 100% wholemeal or other whole grain breads will produce poor results as there is insufficient time for the dough to rise.

The salt level is reduced for this programme as salt retards yeast activity. However, do not eliminate it completely as it is important for taste and texture.

The yeast levels are higher on this programme to help ensure a rapid rise.

If you want to make several loaves in succession on this Ultra Fast programme, leave the Compact Bread Maker switched off for 30 minutes between loaves. This allows the temperature sensor within the Compact Bread Maker to work accurately, which is critical for a short bread cycle.

Breads made on this programme will not rise as high as loaves made on other settings. They will have a softer crust and be a little denser, which is normal.

Ingredients	Quantity
Water - lukewarm	150ml
Oil	2 tablespoons (30ml)
Salt	½ teaspoon
Strong white bread flour	2 cups (320g)
Caster sugar	3 tablespoons
Easy blend yeast	1¼ teaspoons

WHAT YOU DO

Put the ingredients into the bread pan in the order above.

Close the lid.

Press MENU and select programme 7.

Press COLOUR and select LIGHT, MEDIUM or DARK.

Press START/STOP.

When the Compact Bread Maker beeps 10 times you can add any additional ingredients.

The programme will continue until the end and will then beep again 10 times to indicate that the bread is ready.

Press START/STOP and open the lid.

Remove the loaf from the bread pan and leave to cool.

PROGRAMME 8 - DOUGH

Use this programme to make the dough for all sorts of recipes and then bake in the conventional oven. Alternatively, make your bread dough, remove the kneading paddle, reshape the dough adding any additional ingredients and then select the BAKE programme to bake the recipe in the Compact Bread Maker

Here are two suggestions;

BREAD ROLLS - Makes 8

Time to make dough 1 hour 30 minutes.

Rising time approximately 40 minutes.

Oven baking time 15 – 20 minutes.

Ingredients	Quantity
Egg, medium	1
Water	Make up to 180ml with the egg
Salt	1 teaspoon
Strong white bread flour	2 cups (320g)
Caster sugar	1 tablespoon
Unsalted butter, cut into pieces	15g
Milk powder	1 tablespoon
Easy blend yeast	1 teaspoon

Additional ingredients can be added when the machine beeps or at the end of the DOUGH programme.

WHAT YOU DO

Crack the egg into the measuring cup and make up to 180ml with water.

Put all the ingredients in the order above into the bread pan.

Close the lid.

Select the programme 8.

Press the START/STOP button.

The Compact Bread Maker will start immediately.

When the Compact Bread Maker beeps 10 times you can add any additional ingredients.

The programme will continue until the end and will beep again 10 times to indicate that the dough is ready.

Press the START/STOP button and open the lid.

Lift out the bread pan, tip the dough onto a lightly floured worktop and pull out the kneading paddle. Knead very lightly.

Divide the dough into 8 pieces and with lightly floured hands, shape each piece into a ball.

Transfer to a large, greased baking tray.

Cover the rolls with a piece of oiled cling film or a clean tea towel and leave in a warm place for approximately 30 - 40 minutes or until the rolls have doubled in size.

Meanwhile, preheat the oven to 220°C, 425°F, Fan oven 200°C, Gas mark 7.

Brush the rolls with your chosen glaze and sprinkle on the topping.

Bake for 15 - 20 minutes or until golden brown and well risen.

If you like, glaze the tops of the rolls before baking with one of the following;
Beaten egg white, egg yolk beaten with a little water, milk or about 1 tablespoon hot water in which 2 teaspoons of caster sugar has been added.

TOPPINGS;

Sprinkle the tops of the glazed rolls with one of the following;
Poppy, fennel, caraway or sesame seeds.

PROGRAMME 8 - DOUGH CONTINUED

PIZZA - Makes 2 x 20cm pizzas or 1 large pizza

Time to make dough 1 hour 30 minutes.

Oven baking time 20 - 25 minutes.

Ingredients	Quantity
Base	
Water	140ml
Oil	1 tablespoon (15ml)
Salt	1 teaspoon
Strong white bread flour	1¼ cups (225g)
Caster sugar	½ teaspoon
Easy blend yeast	½ teaspoon
Topping	
Tomato purée	4 tablespoons
Dried oregano	2 tablespoons
Tomatoes, sliced	4 large
Cheddar cheese, grated	115g
Mozzarella, sliced	115g
Ham, torn into strips	4 slices
Pitted black olives	10
Olive oil for drizzling	

WHAT YOU DO

Put all the ingredients for the base in the machine in the order above.

Close the lid.

Press MENU and select programme 8.

Press START/STOP.

Ignore the 10 beeps to indicate that extra ingredients can be added.

The programme will continue until the end and will beep again 10 times to indicate that the dough is ready.

Press START/STOP and open the lid.

Tip the dough onto a very lightly floured board.

Pull out the kneading paddle and divide the dough into two pieces.

Preheat the oven to 220°C, Fan oven 200°C, 425°F, Gas mark 7.

Grease one large or two smaller baking trays.

Put the dough onto the tin and gently stretch and pull the dough into a round shape so it fits the tins

Pinch up the edges to make a lip.

TOPPING

Spread the tomato purée over the pizza bases and sprinkle on the oregano.

Arrange the tomato slices on top. Then sprinkle on the grated cheese.

Arrange the Mozzarella slices, ham and olives on top.

Drizzle the pizzas with a little olive oil.

Bake for 20 - 25 minutes until golden, well risen and the cheese is bubbling.

PROGRAMME 9 - CAKE

CHOCOLATE AND WALNUT CAKE - Time to make 1 hour 50 minutes

Check the mixture is mixing correctly - about 5 minutes open the lid and make sure the flour is mixing in evenly. Scrape down the sides of the bread pan to incorporate any stray lumps of flour.

Do not use strong bread flour for cakes - use your usual ordinary flour.

This chocolate cake is moist and delicious.

Ingredients	Quantity
Oil	75ml
Milk	75ml
Soft, light brown sugar	75g
Black treacle	2 teaspoons
Egg, medium	1
Self raising flour	115g
Baking powder	¼ teaspoon
Cocoa powder	25g
Ground almonds	25g
Chocolate chips	25g
Walnuts, roughly chopped	50g

WHAT YOU DO

Put the oil, milk, sugar, treacle and eggs into the bread pan.

Sift together the flour, baking powder and cocoa powder, then add to the pan.

Sprinkle the almonds on top.

Close the lid.

Press MENU and select programme 9.

Press COLOUR and select LIGHT.

Press START/STOP.

The machine will start automatically.

Check the mixture after approximately 5 minutes to check that the ingredients are mixing together. Scrape down the sides to incorporate any flour that remains.

When the machine beeps 10 times, open the lid and add the chocolate and walnuts.

The programme will continue until the end and will then beep again 10 times to indicate that the cake is ready.

Lift out the bread pan and leave to cool for a few minutes before turning out the cake onto a cooling rack.

Allow the cake to cool completely before filling and topping as desired.

FILLING

Chocolate Butter Cream

Ingredients	Quantity
Butter, softened	75g
Icing sugar, sifted	175g
Chocolate, melted	40g
Walnut halves	6

WHAT YOU DO

Cream the butter until soft.

Gradually beat in the icing sugar until smooth and creamy.

Add the melted chocolate and mix together well.

Cut the cake in half and use half the buttercream to sandwich the two pieces together.

Spread the remaining buttercream on top of the cake.

Arrange the walnut halves on top.

PROGRAMME 10 - SANDWICH

SANDWICH LOAF - Time to make 3 hours

Ingredients	Quantity
Egg	1
Water	Make up to 180ml with the egg
Oil	1 tablespoon
Salt	1 teaspoon
Strong white bread flour	2 cups (320g)
Caster sugar	1 tablespoon
Milk powder	1 tablespoon
Easy blend yeast	1 teaspoon

WHAT YOU DO

Crack the egg into the measuring cup.

Add the water to the egg making up the quantity to 180ml.

Put the ingredients into the bread pan in the order above.

Close the lid.

Press MENU and select programme 10.

Press COLOUR and select LIGHT, MEDIUM or DARK.

Press START/STOP.

When the Compact Bread Maker beeps 10 times add any additional ingredients.

The programme will continue until the end and will then beep again 10 times to indicate that the bread is ready.

Press START/STOP and open the lid.

Remove the loaf from the bread pan and leave to cool.

PROGRAMME 11 - BAKE

SUN-DRIED TOMATO, CHEESE AND OLIVE BREAD - Time to make dough 1 hour 30 minutes plus 1 hour bake

A delicious bread which can be made into sandwiches, served with soup or toasted for bruschetta. First of all make the dough using programme 8 DOUGH.

Ingredients	Quantity
Water	180ml
Oil	1 tablespoon
Salt	1 teaspoon
Strong white bread flour	2 cups (320g)
Caster sugar	1 tablespoon
Milk powder	1 tablespoon
Easy blend yeast	1 teaspoon
Parmesan cheese, grated	50g
Sun-dried tomatoes, cut into pieces	50g
Black, pitted olives, cut into pieces	25g

WHAT YOU DO

Put the water, oil, salt, flour, sugar, milk powder and yeast into the bread pan.

Add the Parmesan cheese and 25g of the tomatoes.

Close the lid.

Press MENU and select programme 8 DOUGH.

Press START/STOP.

The Compact Bread Maker will start immediately.

The Compact Bread Maker will beep 10 times to indicate that you can add extra ingredients but ignore the beeps as the remaining tomatoes and olives will be kneaded in by hand at the end of the programme (however, you can add them now if you prefer).

The programme will continue and will beep 10 times at the end of the programme to indicate that the dough is ready.

Press the START/STOP button and open the lid.

Lift out the bread pan, tip the dough onto a lightly floured worktop and pull out the kneading paddle. Knead very lightly.

Flatten the dough out a little and place the remaining tomatoes and olives on top.

With lightly floured hands gently knead the tomatoes and olives evenly into the dough.

Replace the bread pan in the unit without the kneading paddle.

Put the completed dough into the bread pan and close the lid.

Press MENU and select programme 11 BAKE.

The machine will beep 10 times at the end of the baking time.

Press START/STOP and open the lid.

Remove the loaf from the bread pan and leave to cool on a cooling rack.

TROUBLESHOOTING

Following are some common problems that can occur when making bread in your Compact Bread Maker. Please review the problems, their possible cause and any corrective action that should be taken to ensure successful bread making.

Problem	Possible Cause	Solution
Loaf size and shape		
1. Bread does not rise enough.	<p>Wholemeal breads will be lower than white breads due to less gluten.</p> <p>Not enough liquid.</p> <p>Sugar omitted or not enough added.</p> <p>Wrong type of flour used.</p> <p>Wrong type of yeast used.</p> <p>Not enough yeast added or too old.</p> <p>Liquid too hot or too cold and yeast killed or not activated.</p> <p>Yeast and sugar came into contact with each other before kneading cycle.</p> <p>You opened the lid during the rising cycle and allowed warm air to escape.</p>	<p>Normal with this type of flour.</p> <p>Increase liquid by 15ml, 3tsp.</p> <p>Assemble ingredients as listed in the recipe. If you are making sweet bread make sure you reduce the sugar slightly if adding sugary ingredients such as candied fruits etc.</p> <p>You may have used ordinary flour instead of strong bread flour.</p> <p>For best results use fast action "easy blend" yeast.</p> <p>Measure amount recommended and check use by date on packet.</p> <p>Check that liquids are at room temperature before use.</p> <p>Make sure they remain separate when added to the bread pan.</p> <p>Do not open lid during rising.</p>

Problem	Possible Cause	Solution
2. Flat loaf, no rising.	<p>Yeast omitted.</p> <p>Yeast too old.</p> <p>Liquid too hot.</p> <p>Too much salt added or salt came into contact with yeast.</p> <p>Delay start used - yeast became wet before bread making commenced.</p>	<p>Assemble ingredients as listed in recipe.</p> <p>Check use by date on packet.</p> <p>Use liquid at correct temperature for programme.</p> <p>Use amount recommended and keep separate from each other.</p> <p>Add ingredients in correct order making sure yeast cannot come into contact with the liquid.</p>
3. Top inflated - mushroom like in appearance.	<p>Too much yeast.</p> <p>Too much sugar.</p> <p>Too much flour.</p> <p>Not enough salt.</p> <p>Warm, humid weather.</p>	<p>Reduce yeast by ¼ tsp.</p> <p>Reduce sugar by 1 tsp.</p> <p>Reduce flour by 6 - 8 tsp.</p> <p>Use amount of salt recommended in recipe.</p> <p>Reduce liquid by 15ml, 3tsp and yeast by ¼ tsp.</p>
4. Top and sides cave in.	<p>Too much liquid.</p> <p>Too much yeast.</p> <p>High humidity and warm weather may have caused the dough to rise too much.</p>	<p>Reduce liquid by 15ml, 3tsp next time or add a little extra flour.</p> <p>Use amount recommended in recipe or try a quicker programme next time.</p> <p>Chill the water or add milk straight from the fridge.</p>
5. Gnarled and knotted top - not smooth.	<p>Not enough liquid.</p> <p>Too much flour.</p>	<p>Increase liquid by 15ml, 3tsp.</p> <p>Measure flour accurately.</p>

Problem	Possible Cause	Solution
6. Collapsed while baking.	Compact Bread Maker may have been placed in a draught or may have been knocked during rising. Exceeding capacity of bread pan. Not enough salt used or omitted. Too much yeast. Warm, humid weather.	Reposition bread maker. Do not use more ingredients than recommended. Use correct amount of salt. Measure yeast carefully. Reduce liquid by 15ml, 3tsp and reduce yeast by ¼ tsp.
7. Loaves uneven and shorter at one end.	Dough too dry.	Increase liquid by 15ml, 3tsp.
Bread texture		
8. Heavy dense texture.	Too much flour. Not enough yeast. Not enough sugar.	Measure accurately. Measure accurately. Measure accurately.
9. Open, coarse and holey texture.	Salt omitted. Too much yeast. Too much liquid.	Assemble ingredients as listed in the recipe. Measure yeast accurately. Reduce liquid by 15ml, 3 tsp.
10. Centre of loaf is raw, not baked enough.	Too much liquid. Power cut during operation. Quantities too large for machine.	Reduce liquid by 15ml, 3tsp. If power cut lasts for more than 10 minutes you will need to remove the unbaked ingredients from the bread pan and start again with fresh ingredients. Only use maximum quantities allowed.

Problem	Possible Cause	Solution
11. Bread does not slice well and is sticky.	Sliced whilst hot. Wrong knife used.	Allow bread to cool for at least 30 minutes to allow steam to escape before slicing. Use a good quality bread knife.
Crust colour and thickness		
12. Dark crust colour, too thick.	DARK crust colour selected.	Use MEDIUM or LIGHT setting next time.
13. Burnt loaf.	Bread maker malfunctioning.	Refer to customer care section.
14. Crust too light.	Bread not baked long enough. LIGHT crust colour selected.	Carry out a BAKE cycle to darken the crust. Choose DARK or MEDIUM crust colour next time.
Bread pan problems		
15. Kneading paddle cannot be removed from pan.	You must add enough water to cover the kneading paddle and then leave to soak for 10 minutes.	Twist kneading paddle slightly after soaking to loosen.
16. Bread sticks to pan / difficult to shake out.		Lightly wipe the inside of the bread pan with vegetable oil.
Bread maker		
17. Bread maker not operating / kneading paddle not moving.	Bread maker not switched on. Bread pan not correctly located. Time delay selected.	Check the product is turned on. Check pan is locked in place correctly. Bread maker will not start until start time is reached.

Problem	Possible Cause	Solution
18. Ingredients not mixed.	<p>Did not start bread maker.</p> <p>Forgot to put kneading paddle in bread pan.</p>	<p>After selecting programme press the START/STOP button to start machine.</p> <p>Always make sure kneading paddle is positioned correctly on drive shaft in bottom of bread pan before adding ingredients.</p>
19. Burning odour noted on operation.	Ingredients spilled inside baking chamber.	Take care when adding ingredients to bread pan - if ingredients spill into chamber burning can occur.
20. Display screen shows "H HH" and machine beeps continuously.	Temperature inside bread maker is too high - machine still hot after the previous baking procedure.	Press START / STOP button, open lid and allow machine to return to room temperature for 10 - 20 minutes.
21. Display screen shows "L LL" and machine beeps continuously.	Temperature inside maker is too low.	Press START / STOP button, open lid and allow machine to return to room temperature for 10 - 20 minutes.
22. Display screen shows "E EO" or "E E1".	Temperature sensor is faulty.	Contact Lakeland Customer Services for further information.

CARE AND CLEANING

- Always ensure the Compact Bread Maker is switched off and unplugged from the socket and allow to cool completely before cleaning.
- Clean thoroughly before using for the first time and after every use.
- Check the parts for wear or damage after every few uses.
- Do not use metal tools in the non-stick bread pan - always use plastic, nylon or silicone spatulas etc.
- Do not use abrasive cleaners, or steel wool.
- Never immerse the base unit, cord or plug in water or any other liquid.
- Wash the baking pan, kneading paddle, measuring cup and spoon in hot, soapy water, rinse and dry thoroughly.
- The baking pan, kneading paddle, measuring cup and spoon are top shelf dishwasher safe.
- If the kneading paddle is difficult to remove from the bread pan, pour in sufficient warm soapy water to cover the paddle and leave to soak for 10 - 15 minutes. This will loosen the paddle.
- If the kneading paddle still cannot be removed hold the drive shaft from underneath the pan and twist back and forth until the kneading paddle is released.
- To clean the baking chamber, remove any bread crumbs by tipping them out or wiping them away with a slightly damp cloth or clean pastry brush.
- If food residue burns onto the heating element, allow to cool completely then wipe away with a damp cloth.
- Avoid abrasive cleaners and metal scourers as they may damage the machine.
- Store the Compact Bread Maker with the power cable loosely coiled. Never wrap it tightly around the appliance.

ELECTRICAL CONNECTIONS

THIS APPLIANCE MUST BE EARTHED

The appliance is fitted with a fused three-pin plug to BS1363 which is suitable for use in all homes fitted with sockets to current specifications.

CHANGING THE 5 AMP FUSE

Use a 5 amp BS1362 fuse. Only BSI or ASTA approved fuses should be used. If you are unsure which plug or fuse to use, always refer to a qualified electrician.

Note: After replacing or changing a fuse on a moulded plug which has a fuse cover, the cover must be refitted to the plug; the appliance must not be used without a fuse cover. If lost, replacement fuse covers can be obtained from an electrical shop. This appliance complies with the following EU Directives: 2014/35/EU (Low Voltage Directive) and 2014/30/EU (EMC Directive).

RECYCLING YOUR ELECTRICALS

Along with many other high street retailers, Lakeland has joined a scheme whereby customers can take their unwanted electrical products to recycling points set up around the country.

Visit www.recycle-more.co.uk to find your nearest recycling point.



Lakeland

Alexandra Buildings, Windermere, Cumbria, UK LA23 1BQ

Tel: +44(0)15394 88100 www.lakeland.co.uk